



IMC-100C

10/100Base-TX to 100Base-FX Fiber Converter
(Compact)



IMC-100C is a compact sized, unmanaged industrial grade Fast Ethernet media converter that supports conversion between electrical 10/100Base-TX and optical 100Base-FX Ethernet. Simple DIP switch settings allow configuring UTP port for auto-negotiation or for forced 10/100 speed and half/ full duplex as well as for enabling LFPT (Link Fault Pass Through), and selecting Switch Mode (store & forward) or Converter Mode (Jumbo frame Pass-through). Housed in rugged DIN rail or wall mountable enclosures, these converters are designed for harsh environments, such as industrial networking and intelligent transportation systems (ITS) and are also suitable for many military and utility market applications where environmental conditions exceed commercial product specifications (See Figure 1).

Features

- DC input power 12/24/48VDC (9.6 ~ 60VDC) or 24VAC (18~36VAC)
- IP30 rugged metal housing, compact size and fanless
- Wide operating temperature -40 ~ 75°C (IMC-100C-E)
- CE, FCC, railway traffic EN50121-4 certification
- Heavy industrial grad EMS, EMI, EN61000-6-2, EN61000-6-4 certified
- Store-and-Forward mode and Pass Through mode (set by DIP SW)
- Support LFPT (Link Fault Pass Through)
- Conversion between 10/100Base-TX and 100Base-FX cable interface
- Provides a 4 pin DIP-Switch to set functions

Specifications

Standard	IEEE 802.3 10Base-T 10Mbit/s Ethernet IEEE 802.3u 100Base-TX, 100Base-FX, Fast Ethernet IEEE 802.3x Flow Control
RJ45 Ports	10/100Base-TX Auto MDI/MDI-X and Auto-Negotiation Function Supports UTP CAT.5e Twisted Pair cable
Fiber Ports	100Base-FX (SC/ST connectors)
Switch Architecture	Store and Forward in Switch mode Supports 1024 MAC addresses in Switch mode
Ethernet Packet length	2046Byte (Max) in Switch mode
Jumbo Frame	9K bytes in Pass through (Converter mode)
Fiber Parameters	Fiber Cable (Multi-mode): 50/125um,62.5/125um Fiber Cable (Single-mode): 9/125um Wavelength: 1310nm (Multi-mode/Single-mode) Available distance: 2KM (Multi-mode) 30KM (Single-mode) 50KM (Single-mode)
Link Fault Pass Through (LFPT)	TX- Fiber: If TX port link down, the media converter will force Fiber port to link down Fiber-TX: If Fiber port link down, the media converter will force TX port to link down
DIP Switch	Force Fiber port Duplex OFF: Full Duplex ON: Half Duplex LFPT: ON: Enables LFPT (Link Fault Pass through) OFF: Disables LFPT Architecture: OFF: Switching mode ON: Pass through Converter mode
Connector	Fiber: SC (Multi-mode, 2km), SC (Single-mode, 30km, 50KM) ST (Multi-mode, 2km), ST (Single-mode, 30km, 50KM) RJ-45 Socket: CAT.5e (10/100Mbps) Twisted Pair cable Auto MDI/MDI-X and Auto-Negotiation Function Support
LED	PWR (Green): ON: Power active / OFF: Power is inactive Fiber (Green): LNK/Act (Green) : Link & Active Dup (Green) : Fiber port Full or Half duplex LAN:100 (Green): 100M Link & Active 10 (Green): 10M Link & Active
Reverse Polarity Protection	Supported for power input
Overload Current Protection	Supported

Power Supply	12/24/48VDC (9.6~60VDC) or 24VAC (18~36VAC), polarity reverse protect function and removable terminal block									
Power Consumption	<table border="1"> <thead> <tr> <th>Input Voltage</th> <th>Watt(W)</th> </tr> </thead> <tbody> <tr> <td>12VDC</td> <td>1.8W</td> </tr> <tr> <td>24VDC</td> <td>1.8W</td> </tr> <tr> <td>48VDC</td> <td>2.1W</td> </tr> </tbody> </table>	Input Voltage	Watt(W)	12VDC	1.8W	24VDC	1.8W	48VDC	2.1W	
Input Voltage	Watt(W)									
12VDC	1.8W									
24VDC	1.8W									
48VDC	2.1W									
Removable Terminal Block	Provide for 1x DC input power (2 Pin)									
Operating Humidity	5% ~ 95% (Non-condensing)									
Operating Temperature	-40 ~ 75°C (IMC-100C-E)									
Storage Temperature	-40 ~ 85°C									
Housing	IP30 rugged metal housing ,compact size and fanless									
Dimensions	70 x 30 x 103 mm (D x W x H)									
Weight	215g									
Installation	DIN Rail mounting, Wall Mounting (Optional)									
MTBF	1,558,180 Hours (MIL-HDBK-217)									
Warranty	5 years									
Certifications	CE									
EMC	FCC Part 15 Subpart B Class A, CE									
Railway Traffic	EN50121-4									
Immunity for Heavy Industrial environment	EN 61000-6-2									
Emission for Heavy Industrial Environment	EN 61000-6-4									
EMS (Electromagnetic Susceptibility) ProtectionLevel	EN61000-4-2 (ESD) Level 3, Criteria B EN61000-4-3 (RS) Level 3, Criteria A EN61000-4-4 (EFT) Level 3, Criteria A EN61000-4-5 (Surge) Level 3, Criteria B EN61000-4-6 (CS) Level 3, Criteria A EN61000-4-8 (PFMF) Field strength 300A/m Criteria A									
Shock	IEC 60068-2-27									
Freelfall	IEC 60068-2-32									
Vibration	IEC 60068-2-6									

Application

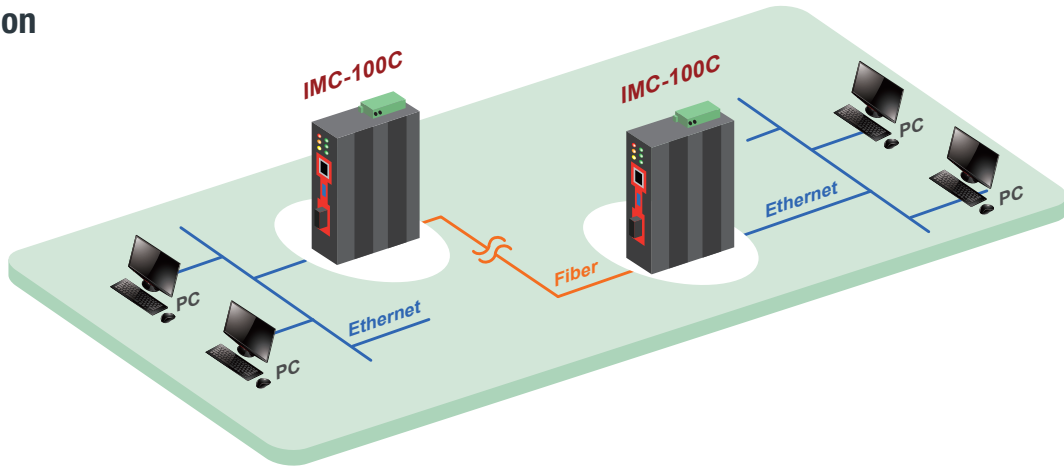
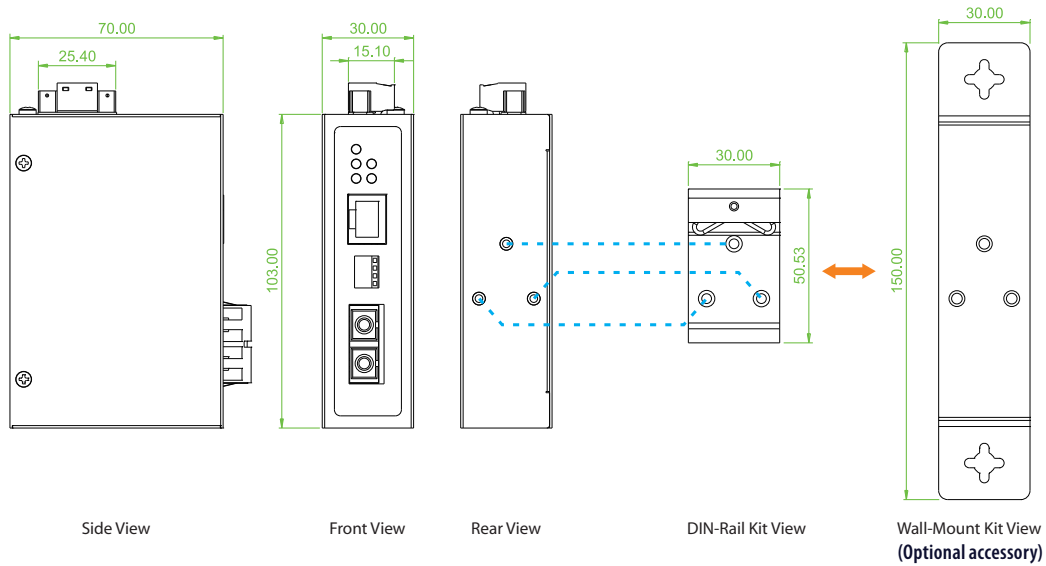

Figure 1 : IMC-100C Media Converter Transmission

Dimensions



Ordering Information

Model Name	RJ45 UTP Port	Fiber	Power Input	Certification				Operating Temperature
	10/100Base-TX	100Base-FX	Single power	Railway EN50121-4	EN61000-6-2 EN61000-6-4	CE	FCC	
IMC-100C-E	1	1 SC	12/24/48VDC	V	V	V	V	-40~75°C

Model Naming Rule



Industrial
Media
Converter

100C: 100Base-X Converter
(Compact)

Connector Type	Connectivity Distance
SC, ST	002:2km (M/M) 030:30km (S/M) 050:50km (S/M) 020A: WDM 20km A type (TX:1310nm) 020B: WDM 20km B type (TX: 1550nm)

Optional Accessories

Wall mount kit Accessories

IND-WMK03	Wall Mount kit for Industrial product (Compact, 150x 30mm)
-----------	--

Temperature Connector Type Connectivity Distance
IMC - 100C - [] - [] [] [] [] []
 Example: IMC - 100C - E - SC002

Package List

- IMC-100C device
- Quickly installation guide
- Din Rail bracket with screws
- Terminal block