

Preliminary



## ITP-802GSM

EN50155 IP67 Managed 8x 10/100Base-TX +  
2x100/1000Base-X SFP Ethernet Switch

## ITP-802GTM

EN50155 IP67 Managed 8x 10/100Base-TX +  
2x100/1000Base-X Ethernet Switch

## ITP-800M

EN50155 IP67 Managed 8x 10/100Base-TX Eth, Switch

ITP-802GSM系列產品為管理型工業等級百兆乙太網交換器，配備8個10/100Base-TX 端口和 2 個SFP 或UTP千兆/高速乙太網端口，可用以提供穩定而可靠的乙太網傳輸能力。此系列產品其他Layer 2 乙太網交換機管理功能，包括STP/RSTP/MSTP/ITU-T G.8032 Ring 及 multiple u-Ring的備援佈線、Layer 2 乙太網 IGMP、VLAN、QoS、Security、IPv6、bandwidth control、port mirroring、纜線診斷和節能乙太網(Green Ethernet)。這些交換器位於堅固的DIN軌道或壁掛機箱內，專為最嚴苛環境所設計。此系列交換器特別採用M12接頭，以確保緊密、牢固的連接，同時保證其可靠運作，免於振動和撞擊等環境干擾。此系列產品通過EN 50155認證，具備防電源輸入電壓變動、突波、EFT、ESD、振動和撞擊功能，因此本系列交換器極適合車輛、鐵路車輛、船舶、船隻等工業應用。此系列產品具備IP67等級防塵及防水保護功能，它們尤其適合在極端溫度、高溼度、油、灰塵的環境中，以及需要防水功能的戶外環境(例如IP監視、都市維安)使用，以及使用於需要防水防塵的工業環境(如水廠、化工廠、高粉塵的工廠等)使用。此系列產品也可搭配CTC管理平台SmartView™使用，以提供便利、即時且集中式的網路管理。

### 功能特色

- 8 個 10/100Base-TX M12 及 2 個 100/1000Base-X SFP Fiber (共 10 個端口) (ITP-802GSM)
- 8 個 10/100Base-TX M12 及 2 個 100/1000Base-T (共 10 個端口) (ITP-802GTM)
- 8 個 10/100Base-TX M12 (共 8 個端口) (ITP-800M)
- M12 和 M23 連接器能有效抗震及防撞
- IP67 防水設計能有效防塵防水
- 雙電源冗餘備援輸入。可選擇低電壓的 12/24/48VDC 或高電壓的 (110/220/240VAC 或 110/220/240VDC) 輸入電源
- 通過 UL60950-1, CE, FCC, 鐵道交通 EN50155, EN50121-4 認證
- 通過工業級 EMS(抗電磁干擾), EMI (電磁波干擾), EN61000-6-2, EN61000-6-4 認證
- 支援網路線斷線診斷，可以診斷網路線故障點，定位線纜的故障點距離
- 支援綠色節能乙太網 IEEE802.3az EEE (Energy Efficient Ethernet) Management，優化電源消耗
- STP, RSTP, MSTP, ITU-T G.8032 Ethernet Ring Protection Switch(ERPS)
- 每台設備可支援 u-Ring, u-Chain 或 Sub-Ring 型態的環網(圖 4)，最多可設 5 個環網
- u-Ring 冗餘乙太網環網，在最多 250 個裝置時，恢復時間 <10ms
- DHCP client/Relay/Snooping/Snooping option 82/Relay option 82
- QoS, Traffic classification QoS, CoS, bandwidth control for Ingress and Egress, Storm Control, DiffServ
- IEEE802.1q VLAN, MAC based VLAN, IP subnet based VLAN, Protocol based VLAN, VLAN translation, GVRP, MVR
- Dynamic IEEE 802.3ad LACP Link Aggregation, Static Link Aggregation
- IGMP snooping V1/V2/V3, IGMP Filtering/ Throttling, IGMP query, IGMP proxy reporting, MLD snooping V1/V2
- Security: Port based 和 MAC based IEEE802.1X, RADIUS, ACL, TACACS+, HTTP/HTTPS, SSL/SSH v2
- 支援透過 TFTP 和 HTTP 進行軟體升級，韌體冗餘備份防止升級失敗
- 支援 IEEE1588 PTP V2 精密時間同步，可選擇以下模式操作 Master, Boundary, Slave mode by each port
- 支援 RMON, MIB II, Port mirroring, Event syslog, DNS, NTP/SNTP, IEEE802.1ab LLDP
- 支援 IPv6 Telnet server/ICMP v6
- 支援 CLI, Web based management, SNMP v1/v2c/v3, Telnet server 管理方式
- 支援 SmartConfig™，提供快速且便利的設定工具，以便於設定大量的設備
- 支援 SmartView™ 集中式的管理系統

### 產品規格

符合標準	IEEE 802.3 10Base-T 10Mbit/s Ethernet
	IEEE 802.3u 100Base-TX, 100Base-FX, Fast Ethernet
	IEEE 802.3ab 1000Base-T Gbit/s Ethernet over twisted pair
	IEEE 802.3z 1000Base-X Gbit/s Ethernet over Fiber-Optic
	IEEE 802.1d STP (Spanning Tree Protocol)
	IEEE 802.1w RSTP (Rapid Spanning Tree Protocol)
	IEEE 802.1s MSTP (Multiple Spanning Tree Protocol)
	ITU-T G.8032 / Y.1344 ERPS (Ethernet Ring Protection Switching)
	IEEE 802.1Q Virtual LANs (VLAN)
	IEEE 802.1X Port based and MAC based Network Access Control, Authentication
	IEEE 802.3ad Link aggregation for parallel links with LACP(Link Aggregation Control Protocol)
	IEEE 802.3x Flow control for Full Duplex
	IEEE 802.1ad Stacked VLANs, Q-in-Q
	IEEE 802.1p LAN Layer 2 QoS/CoS Protocol for Traffic Prioritization
	IEEE 802.1ab Link Layer Discovery Protocol (LLDP)
	IEEE 802.3az EEE (Energy Efficient Ethernet)
VLAN ID	4094 IEEE802.1Q VLAN VID
Switch Architecture	Back-plane (Switching Fabric): 5.6Gbps (ITP-802GSM, ITP-802GTM) 1.6Gbps (ITP-800M)
Data Processing	Store and Forward

Flow Control	IEEE 802.3x (全雙工), Back pressure(半雙工)
網路連接器	8個M12 (4-Pin, Female, D-Code) 10/100Base-TX 支援auto negotiation speed, 自動 MDI/MDI-X 等功能 全/半雙工 防水 Fiber Cable Gland 支援 2 個 100/1000 Base-X 雙速mode SFP 端口, 使用 DDMI (ITP-802GSM) 2x M12 (8-Pin, female, A-Code) 10/100/1000Base-T (ITP-802GTM) 內建 2 bypass 端口port (ITP-802GTM)
Console	RS-232 (5-pin A-Code M12 male)
網路線規格	UTP/STP above Cat. 5e cable EIA/TIA-568 100-ohm (100m)
通訊協議	CSMA/CD
電壓極性保護	提供
電流過載保護	提供
CPU Watch Dog	提供
LED指示燈	Power 1 (綠), Power 2 (綠), Fault (琥珀色), CPU Act(綠), Ring Master(黃) P1~8 UTP端口: 10/100 Link/Active(綠) P9, P10: 10/100 Link/Active(綠), (for ITP-802GTM) 1000 Link/Active(琥珀色) 每SFP Fiber 端口: Link/Active(綠)
Jumbo Frame	9.6KB
MAC Address Table	8K
Memory Buffer	256K Bytes for packet buffer

電源供應	提供1個M23(5-Pin, male)可接雙輸入電源冗餘備援 可選購低電壓或高電壓輸入電源 低電壓: 12/24/48VDC(8.4~60VDC) 高電壓: 110/220/240VAC (88~265VAC) 或 110/220/240VDC (88~300VAC)
耗電量	TBD
告警方式	System Syslog, SMTP/ e-mail event message, alarm relay
告警繼電器規格	5-pin A-code M12 male Relay outputs with current carrying capacity of 1 A @24VDC
工作溫度	-10 ~ 60°C (ITP-802GSM, ITP-802GTM, ITP-800M) -40 ~ 75°C (ITP-802GSM-E, ITP-802GTM-E, ITP-800M-E)
工作濕度	5% to 95% (無冷凝)
儲存溫度	-40 ~ 85°C
外殼	金屬外殼, IP67防水防塵保護、無風扇
尺寸	70x240x168mm (D x W x H)
重量	TBD
安裝方式	Din Rail 軌道式安裝或壁掛式
MTBF	TBD (MIL-HDBK-217)
產品保固	5年

## 軟體規格

<b>Topology</b>	
VLAN	IEEE 802.1q VLAN, up to 4094 802.1Q VLAN VID IEEE 802.1q VLAN, up to 4094 Groups IEEE 802.1ad Q-in-Q MAC-based VLAN, up to 256 entries IP Subnet-based VLAN, up to 128 entries Protocol-based VLAN(Ethernet, SNAP, LLC), up to 128 entries VLAN Translation, up to 256 entries GVRP (GARP VLAN Registration Protocol) MVR ( Multicast VLAN Registration )
Link Aggregation (Port Trunk)	Static (Hash with SA, DA, IP, TCP/UDP port), up to 5 trunk group Dynamic (IEEE 802.3ad LACP), up to 5 trunk group
Spanning Tree	IEEE802.1d STP, IEEE802.1w RSTP, IEEE802.1s MSTP
Multiple u-Ring	up to 5 instances that each supports u-Ring, u-Chain or Sub-Ring type for flexible uses, and maximum up to 5 Rings. 恢復時間 <10ms 每個環最多可達250個設備
Loop Protection	Present
ITU-T G.8032 / Y.1344 ERPS (Ethernet Ring Protection )	恢復時間 <50ms
QoS特色	Single Ring, Sub-Ring, Multiple ring topology network
Class of Service	IEEE802.1p 8 active priorities queues for per port
Traffic Classification	IEEE802.1p based CoS
QoS	IP Precedence based CoS IP DSCP based CoS QCL(QoS Control List): Frame Type, Source/ Destination MAC, VLAN ID, PCP, DEI QCE(QoS Control Entry): Protocol, Source IP, IP Fragment, DSCP, TCP/UDP port number
Bandwidth Control for Ingress	Rate in steps :1 kbps / Mbps / fps / kfps Range : 100 kbps to 1Gbps / 1fps to 3300kfps Rate Unit : bit or frame
Bandwidth Control for Egress	Rate in steps : 1 kbps / Mbps Range : 100 kbps to 1Gbps Rate Unit : bit Per queue / Per port shaper
DiffServ (RF 2474)	Remarking
Storm Control	for Unicast, Broadcast, Multicast
<b>IP Multicasting 特色</b>	
IGMP / MLD Snooping	IGMP Snooping v1, v2, v3 / MLD Snooping v1, v2 Port Filtering Profile, Throttling
IGMP / MLD Snooping	Fast Leave Maximum Multicast Group : up to 1022 entries Query / Static Router Port
<b>Security Features</b>	
IEEE 802.1X	Port-Based MAC-Based
ACL	Number of rules : up to 256 entries for L2 / L3 / L4

<b>認證</b>	
EMC	CE
EMI (Electromagnetic Interference)	FCC Part 15 Subpart B Class A, CE EN55022 Class A
軌道交通	EN50155, EN50121-4
重工業環境 抗電磁干擾	EN61000-6-2
重工業環境 電磁輻射干擾	EN61000-6-4
EMS (Electromagnetic Susceptibility) 抗電磁干擾等級	EN61000-4-2 (ESD) Level 3, Criteria B EN61000-4-3 (RS) Level 3, Criteria A EN61000-4-4 (Burst) Level 3, Criteria A EN61000-4-5 (Surge) Level 3, Criteria B EN61000-4-6 (CS) Level 3, Criteria A EN61000-4-8 (PFMF, Magnetic Field) Field Strength: 300A/m, Criteria A
Safety	UL60950-1 (Pending)
防撞擊	IEC-61373
防摔	IEC 60068-2-32
防震	IEC-61373

<b>RADIUS authentication &amp; accounting</b>	
TACACS+ authentication & accounting, TACACS+ 3.0	
HTTPS, HTTP	
SSL / SSH v2	
User Name Password Authentication	Local Authentication Remote Authentication (via RADIUS / TACACS+)
Management Interface Access Filtering	Web, Telnet / SSH , CLI RS-232 console
<b>Management 特色</b>	
CLI	Cisco® like CLI
<b>Web Based Management</b>	
Telnet	Server
SNMP	V1, V2c, V3
SW & Configuration Upgrade	TFTP, HTTP 有備援韌體以防程式升級失敗
RMON	RMON I (1, 2, 3, 9 group), RMON II
MIB II	RFC 1213
DHCP	Client, Relay, Snooping Snooping option 82, Relay option 82
<b>IP Source Guard</b>	
<b>Port Mirroring</b>	
Event Syslog	Syslog server (RFC3164) (Support 1 server )
Warning Message	System syslog, e-mail, alarm relay
DNS	Client, Proxy
IEEE1588 PTP V2	Master ,Boundary, Slave Operating mode Operating in each port of these switch
<b>NTP / SNTP</b>	
LLDP (IEEE 802.1ab)	Link Layer Discovery Protocol LLDP-MED
<b>IPv6特色</b>	
IPv6 Management	Telnet Server/ICMP v6
SNMP over IPv6	
HTTP over IPv6	
SSH over IPv6	
IPv6 Telnet Support	
IPv6 NTP / SNTP Support	
IPv6 TFTP Support	
IPv6 QoS	
IPv6 ACL	Number of rules: up to 256 entries L2 / L3 / L4
<b>其他特色</b>	
Green Ethernet	支援 IEEE802.3az EEE (Energy Efficient Ethernet)優化電源消耗 依照網路線長短, 自動調節功耗, 以節省短線時的耗電 網路埠無連接時, 自動降低輸出功耗 LED 功率管理 :調節LED強度
Cable Diagnostic	偵測網路線的故障點距離

應用圖



圖1 : ITP Series in Onboard Train Application



圖2 : ITP Series for Industrial Automation

u-Ring Configuration Auto-refresh  Refresh

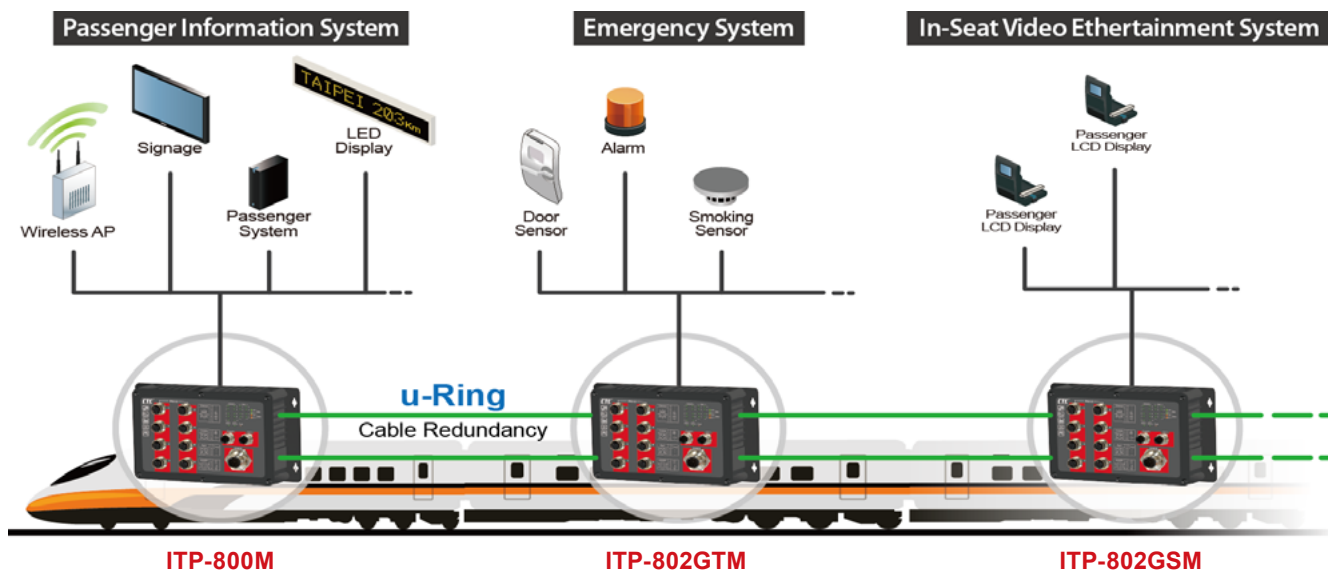
Delete	Instance	Type	Master	East		West	
				Port	Edge	Port	Edge
Delete	1	u-Ring	<input type="checkbox"/>	1		2	
Delete	2	u-Ring	<input type="checkbox"/>	4		3	
Delete	3	u-Ring	<input type="checkbox"/>	10 (Fiber2)		11 (Fiber3)	
Delete	4	Sub-Ring	<input type="checkbox"/>	6			
Delete	5	u-Chain	<input type="checkbox"/>	5	<input type="checkbox"/>	9 (Fiber1)	<input type="checkbox"/>

Add New Instance

Save Reset

圖3 : 方便又容易設定的 u-Ring 功能設定Web 畫面

圖4 : u-Ring 類型



圖5 : u-Ring配置範例

- u-Ring
- Sub-Ring

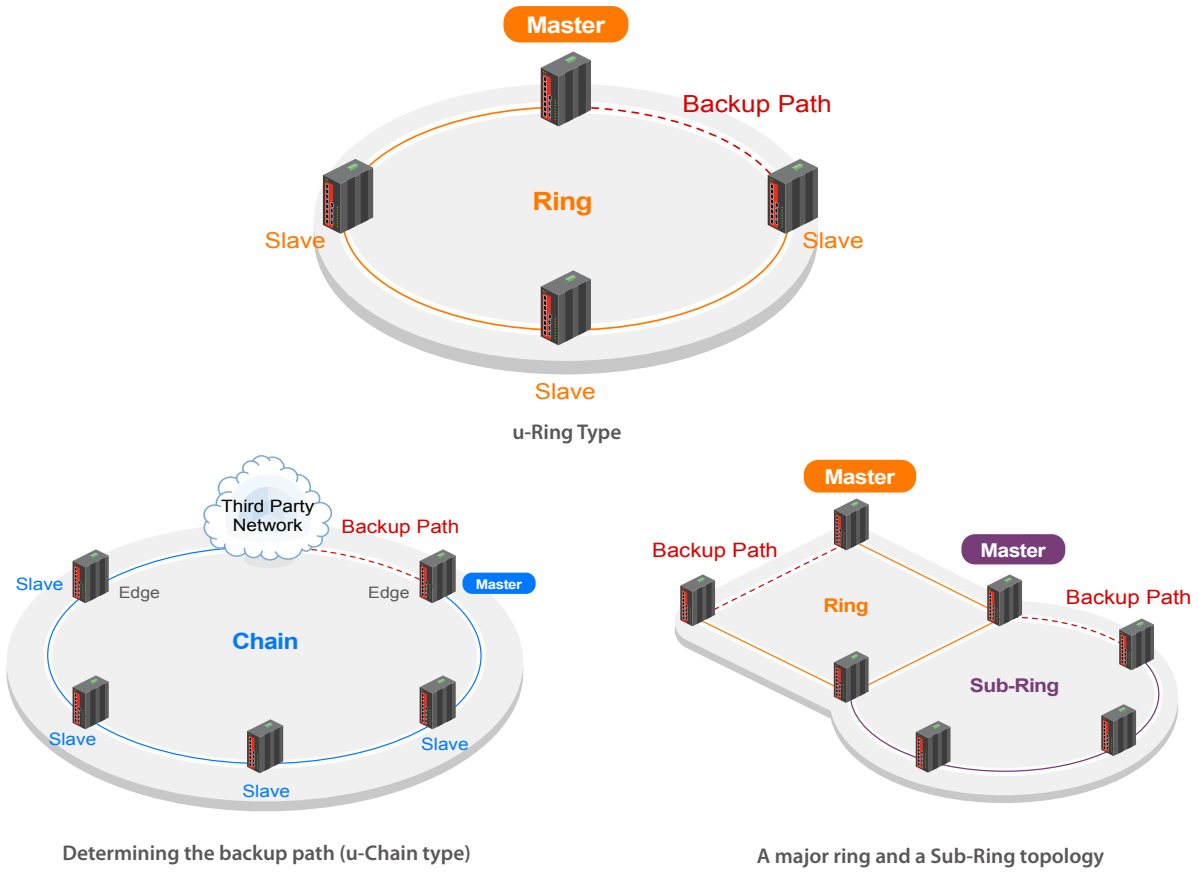
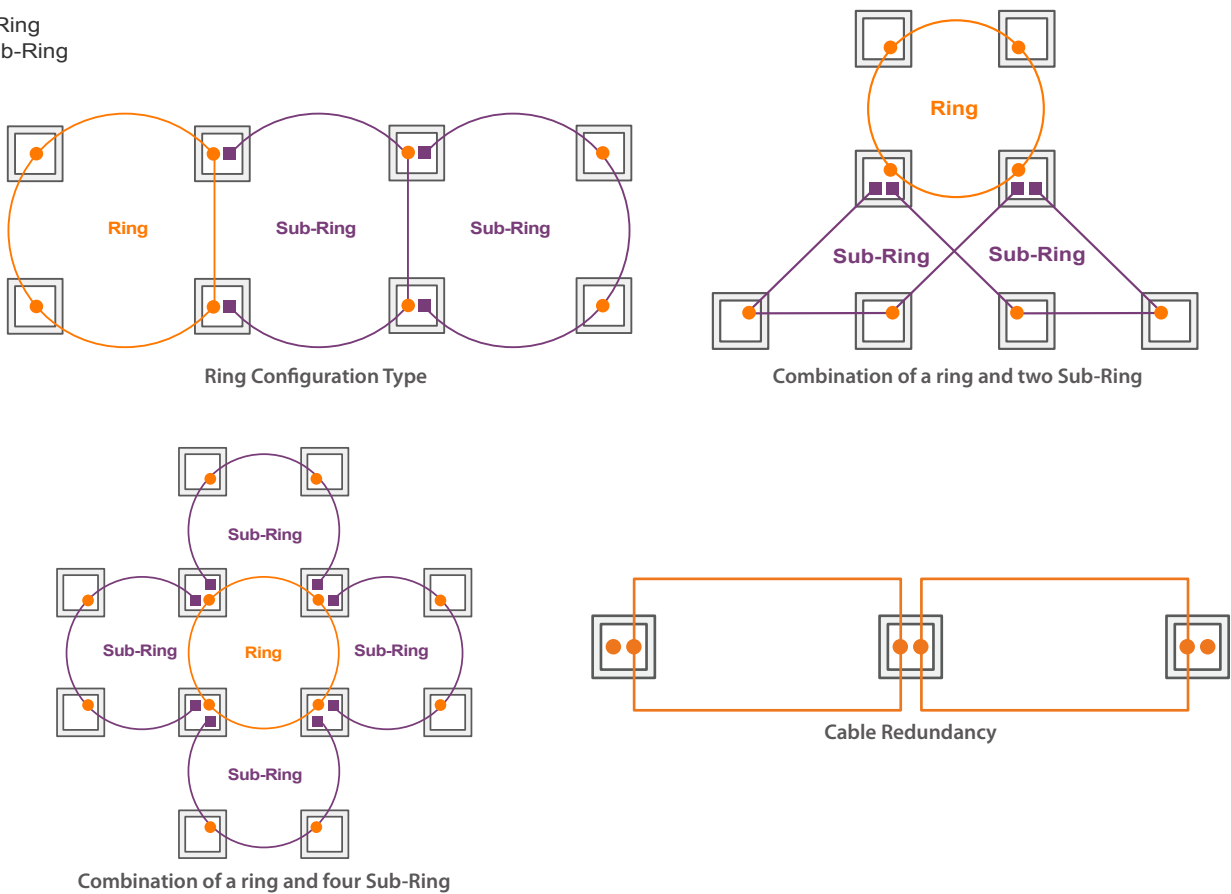

## 機構尺寸

ITP-802GSM

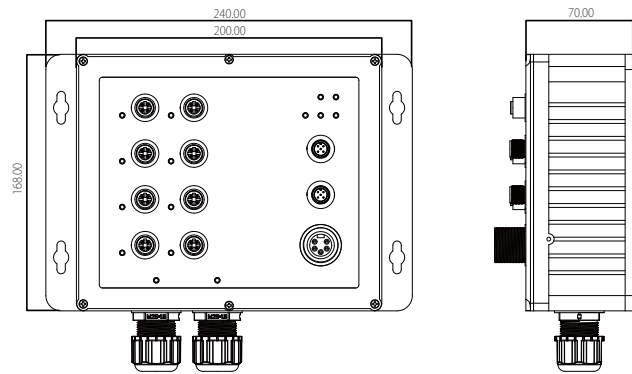

ITP-802GTM

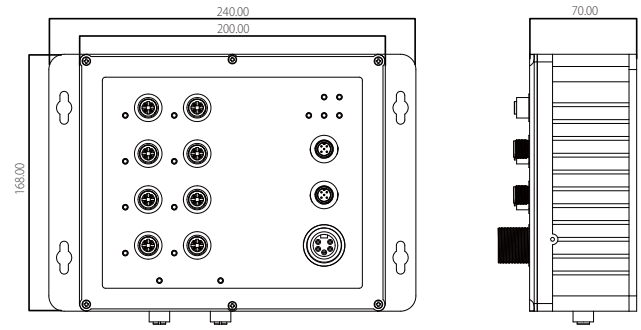

ITP-800M

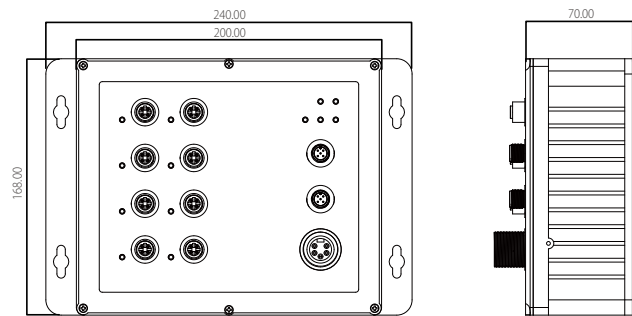

## 訂購資訊

型號	管理	IP67	總埠數	UTP Port M12	Gigabit Port	電源供應		認證				防震	操作溫度
						10/100 Base-TX	Low Volt 12/24/48VDC (8.4~60VDC)	High Volt 110/220 VDC 110/220 VAC	EN50155 EN50121-4	安全 UL60950-1	EN61000-6-2 EN61000-6-4		
ITP-802GSM-LL	V	V	10	8	2 SFP	2	—	V	Plan	V	V	V	-10~60°C
ITP-802GSM-HL	V	V	10	8	2 SFP	1	1	V	Plan	V	V	V	-10~60°C
ITP-802GSM-ELL	V	V	10	8	2 SFP	2	—	V	Plan	V	V	V	-40~75°C
ITP-802GSM-EHL	V	V	10	8	2 SFP	1	1	V	Plan	V	V	V	-40~75°C
ITP-802GTM-LL	V	V	10	8	2 UTP	2	—	V	Plan	V	V	V	-10~60°C
ITP-802GTM-HL	V	V	10	8	2 UTP	1	1	V	Plan	V	V	V	-10~60°C
ITP-802GTM-ELL	V	V	10	8	2 UTP	2	—	V	Plan	V	V	V	-40~75°C
ITP-802GTM-EHL	V	V	10	8	2 UTP	1	1	V	Plan	V	V	V	-40~75°C
ITP-800M-LL	V	V	8	8	—	2	—	V	Plan	V	V	V	-10~60°C
ITP-800M-HL	V	V	8	8	—	1	1	V	Plan	V	V	V	-10~60°C
ITP-800M-ELL	V	V	8	8	—	2	—	V	Plan	V	V	V	-40~75°C
ITP-800M-EHL	V	V	8	8	—	1	1	V	Plan	V	V	V	-40~75°C

### 型號命名規則

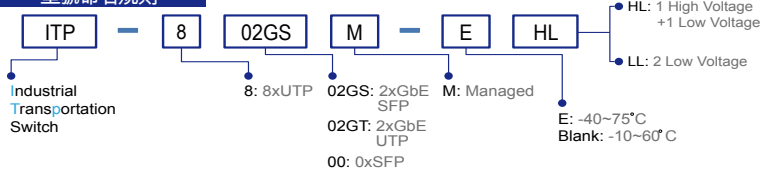

### 選購配件

<b>DR-4524</b>	Industrial Power, Input 85 ~ 264VAC, Output 24VDC, 48W, -10 ~ +50°C
<b>MDR-40-24</b>	Industrial Power, Input 85 ~ 264VAC, Output 24VDC, 40W, -20 ~ +70°C
<b>SFP 收發器</b>	Compatible, Reliable, 5-year Warranty

### SFP命名規則

