



IFS-401F
4x10/100Base-TX +
1x100Base-FX

IFS-500
5x10/100Base-TX

IFS-402F
4x10/100Base-TX +
2x100Base-FX

IFS-800
8x10/100Base-TX

此系列產品為4~8個10/100BASE-TX，及0~2個100Base-FX光纖端口的非網管型工業級千兆乙太交換器，可提供穩定且可靠的乙太網路傳輸。搭配堅固的Din Rail 軌道式或壁掛安裝外殼，此產品專為惡劣環境，如工業網路，安全自動化應用，智能交通系統（ITS），也適用於許多環境條件超出一般商規產品規格的軍事和公用事業的市場應用中。此系列產品也能達到標準工作溫度範圍（-10~60℃）及寬工作溫度範圍（-40~75℃）以滿足工業自動化特殊應用的需求。

功能特色

- 雙電源輸入 12/24/48VDC(9.6~60VDC) 冗餘備援
- 金屬外殼、IP30 防護、無風扇
- 寬溫工作範圍（-40 ~ 75℃）“E” 系列產品
- 提供 broadcast storm protection
- 支援 DIP SW for alarm setting and broadcast storm protection
- 支援 power failure alarm message by relay
- 支援 Flow control
- 通過 CE, FCC, EN50121-4 認證
- 通過工業級 EMS(抗電磁干擾), EMI (電磁波干擾), EN61000-6-2, EN61000-6-4 認證

產品規格

IEEE Standard	IEEE 802.3 10Base-T Ethernet IEEE 802.3u 100Base-TX and 100Base-FX Fast Ethernet IEEE 802.3x Flow Control and Back Pressure	電源供應	雙電源輸入12/24/48VDC(9.6~60VDC) 冗餘備援(可拔插式配接器) Provide DC Power JACK adapter cable for external power supply
Switch Architecture	Back-plane (Switching Fabric) : 1.0 Gbps (IFS-401F) 1.2Gbps (IFS-402F) 1.0 Gbps (IFS-500) 1.6Gbps (IFS-800)	耗電量	4.4W (IFS-401F) 5.8W (IFS-402F) 2.9W (IFS-500) 3.9W (IFS-800)
Data Processing	Store and Forward	告警繼電器規格	Relay outputs with current carrying capacity of 1 A @24VDC, NC
封包傳輸速率	14,880pps (10Base-T) 148,800pps (100Base-TX)	可插拔式配接器	提供一個6針可拔插式配接器。內含2個備援輸入電源，一個告警繼電器
Flow Control	IEEE 802.3x flow control (全雙工), back pressure(半雙工)	工作溫度	-10 ~ 60°C (IFS-401F, IFS-402F, IFS-500, IFS-800) -40 ~ 75°C (IFS-401F-E, IFS-402F-E, IFS-500-E, IFS-800-E)
Provides Broadcast Storm Protection	提供	工作濕度	5% to 95% (無冷凝)
MAC Address Table	2K	儲存溫度	-40 ~ 85°C
Packet Buffer Size	448Kbits	外殼	金屬外殼、IP30防護、無風扇
網路連接器	4X RJ-45, 1 Fiber (IFS-401F) 4X RJ-45, 2 Fiber (IFS-402F) 5x RJ-45 (IFS-500) 8x RJ-45 (IFS-800) RJ-45Port: 自動 MDI/MDI-X function, 10/100Base-TX auto negotiation, 全/半雙工 100Base-FX Fiber Port : SC/ST, Multi Mode/Single Mode	尺寸	106 x 38 x 142mm (D x W x H) (IFS-401F, IFS-402F) 106 x 31.6 x 142mm (D x W x H) (IFS-500, IFS-800)
網路線規格	10Base-T: 2-pair UTP/STP Cat. 5 cable EIA/TIA-568 100-ohm (100m) 100Base-TX: 2-pair UTP/STP Cat. 5 cable EIA/TIA-568 100-ohm (100m) Fiber Cable (Multi-mode): 50/125um~62.5/125um Fiber Cable (Single-mode): 8/125um~10/125um 波長: 1310nm (Multi-mode/Single-mode) 適用距離: 2KM (Multi-Mode) 30KM (Single-Mode) 50KM (Single Mode)	重量	0.625公斤 (IFS-401F) 0.63公斤 (IFS-402F) 0.42公斤 (IFS-500) 0.4公斤 (IFS-800)
通訊協議	CSMA/CD	安裝方式	Din Rail 軌道式安裝或壁掛式
LED指示燈	Power 1 (綠), Power 2 (綠), Fault (琥珀色) RJ-45 連接埠 : Link/Active(綠), 速度100(黃) 光纖埠per Port: Link/Active(綠) (IFS-401F, IFS-402F)	MTBF	587,670小時 (IFS-401F) 509,883小時 (IFS-402F) 650,473小時 (IFS-500) 552,587小時 (IFS-800) (MIL-HDBK-217)
DIP SW	DIP 1 OFF: Enable power failure alarm ON: Disable power failure alarm DIP 2 OFF: Enable broadcast storm protection ON: Disables broadcast storm protection	產品保固	5年
電壓極性保護	提供	認證	
電流過載保護	提供	EMC/EMS	CE
		EMI (Electromagnetic Interference)	FCC Part 15 Subpart B Class A, CE EN55022 Class A
		軌道交通	EN50121-4
		重工業環境 抗電磁干擾	EN61000-6-2
		重工業環境 電磁輻射干擾	EN61000-6-4
		EMS 抗電磁干擾等級	EN61000-4-2 (ESD) Level 3, Criteria B EN61000-4-3 (RS) Level 3, Criteria A EN61000-4-4 (Burst) Level 3, Criteria A EN61000-4-5 (Surge) Level 3, Criteria B EN61000-4-6 (CS) Level 3, Criteria A EN61000-4-8 (PFMF, Magnetic Field) Field Strength: 300A/m, Criteria A
		Safety	UL60950-1 (Pending)
		防撞擊	IEC 60068-2-27
		防摔	IEC 60068-2-32
		防震	IEC 60068-2-6

應用圖



圖1：IFS-402F Fast Ethernet Switch Transmission with Daisy Chain



圖2：IFS-500 Fast Ethernet Switch Transmission

機構尺寸

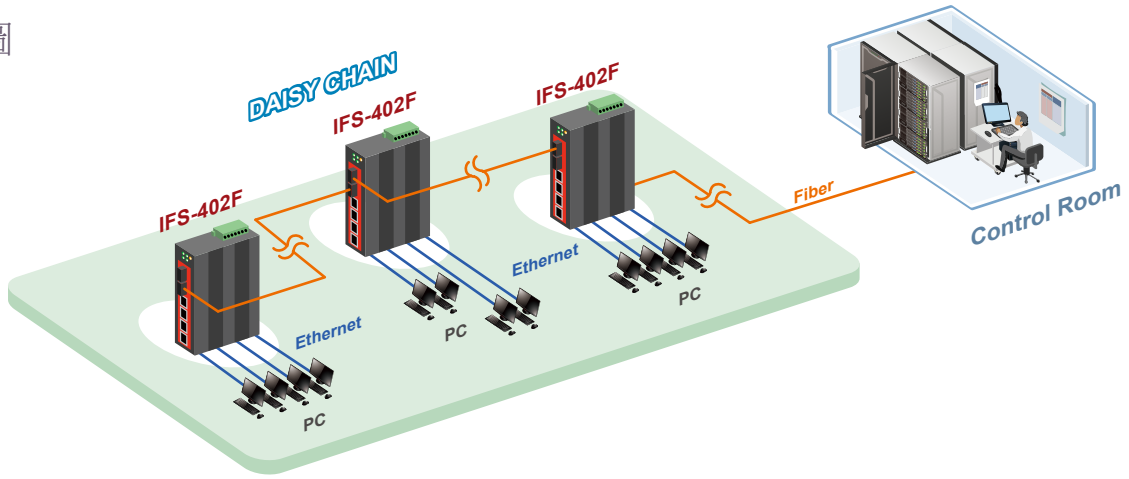

Specifications & design are subject to change without prior notice. Please visit CTC Union website for more details.

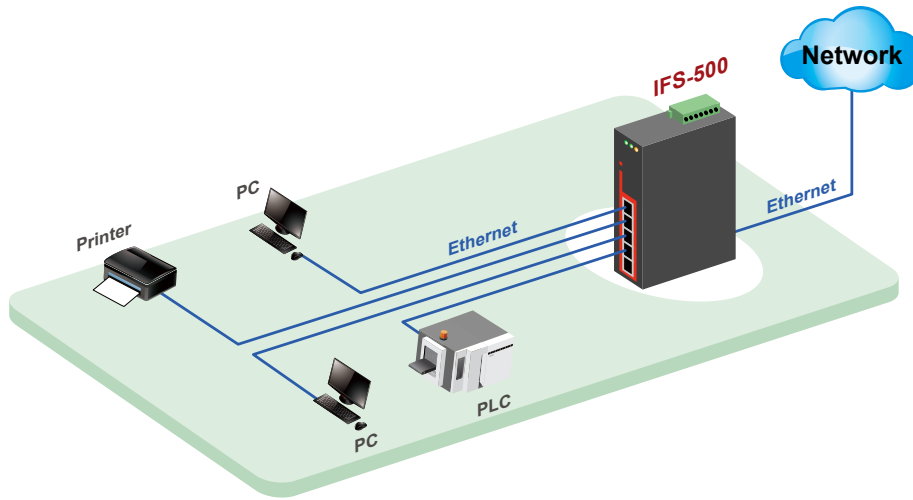
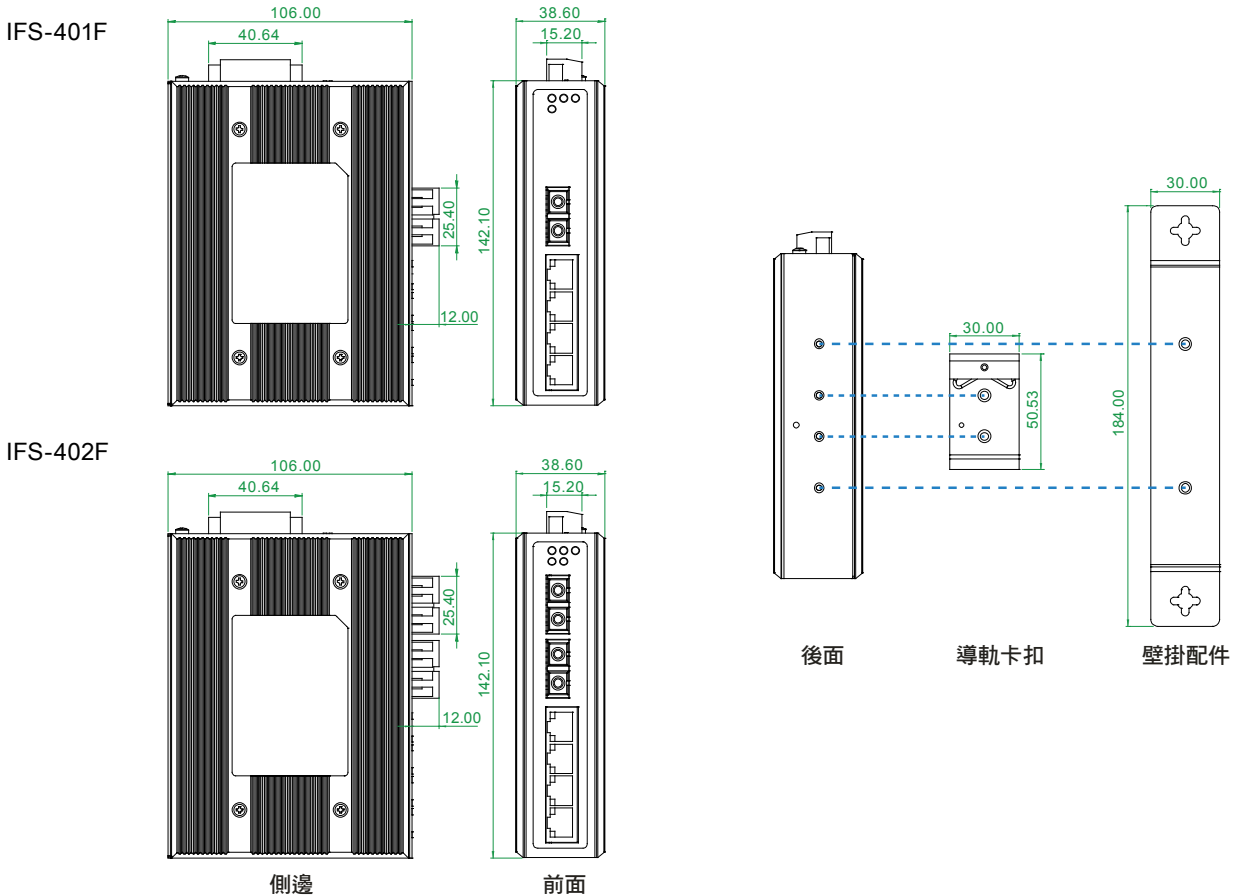
IFS-500

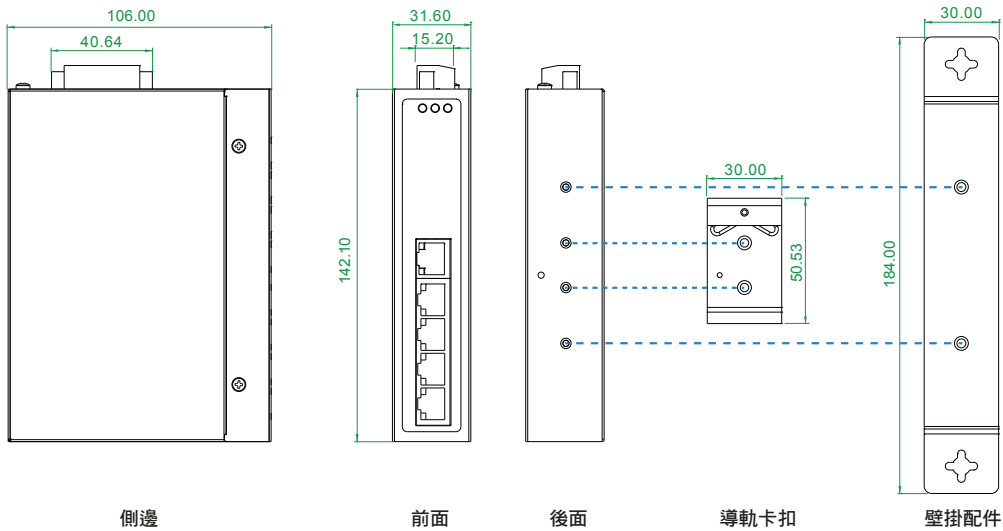

側邊

前面

後面

導軌卡扣

壁掛配件

IFS-800

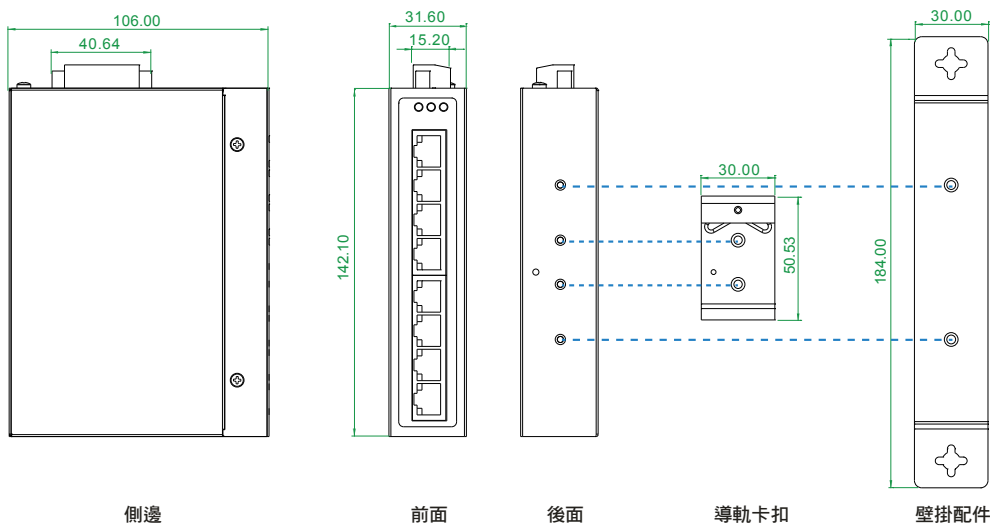

側邊

前面

後面

導軌卡扣

壁掛配件

訂購資訊

型號	總埠數	UTP		光纖		認證			操作溫度	
		10/100Base-TX		100Base-FX		鐵道交通 EN50121-4	EN61000-6-2 EN61000-6-4	CE		FCC
IFS-401F	5	4		1 SC/ST		V	V	V	V	-10~60°C
IFS-401F-E	5	4		1 SC/ST		V	V	V	V	-40~75°C
IFS-402F	6	4		2 SC/ST		V	V	V	V	-10~60°C
IFS-402F-E	6	4		2 SC/ST		V	V	V	V	-40~75°C
IFS-500	5	5		—		V	V	V	V	-10~60°C
IFS-500-E	5	5		—		V	V	V	V	-40~75°C
IFS-800	8	8		—		V	V	V	V	-10~60°C
IFS-800-E	8	8		—		V	V	V	V	-40~75°C

型號命名規則

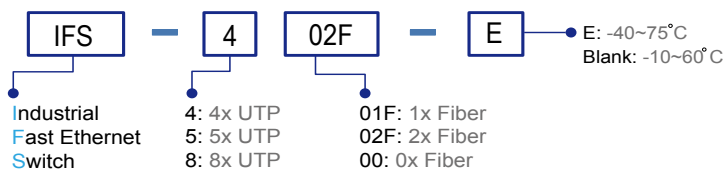

Fiber Option Type	Connectivity Distance
SC, ST	002: 2km 030: 30km 050: 50km
(only for IFS-401F, IFS-402F)	020A: WDM 20km A type (TX: 1310nm)
	020B: WDM 20km B type (TX: 1550nm)

選購配件

DR-4524	Industrial Power, Input 85 ~ 264VAC, Output 24VDC, 48W, -10 ~ +50°C
MDR-40-24	Industrial Power, Input 85 ~ 264VAC, Output 24VDC, 40W, -20 ~ +70°C

Temperature Connector Type Connectivity Distance
IFS - 401F - [] - [] [] [] []
 Example: IFS - 401F - E - SC002